



# Cab Air Conditioning For Motorhomes

## In-Dash

Cab air conditioning systems available for all makes and models to provide the user with the look and performance of a factory fitted system.



*	Citroen Relay
*	Fiat Ducato
*	Ford Transit
*	Iveco Daily
*	Mercedes Sprinter
*	Peugeot Boxer
*	Renault Master
*	Volkswagen Transporter

## Rear Systems

Bespoke Rear systems can provide the user with heating and cooling solutions.

*	In-Dash + Rear Systems
*	Rear Only Systems
*	Rear systems with OE In-Dash Systems
*	Cool Only / Heat + Cool
*	Systems on a supply only or supply and fit basis
*	24 months warranty
*	Quality & Reliability



*If you have never experienced the best in air conditioned travel you simply do not know how pleasurable driving can be. You can enjoy clean, fresh air even in the heaviest traffic. Remain cool, calm and collected in the hottest weather. Discover the safety benefits of not having your windows down and also by keeping alert, comfortable and in complete control.*

**01483 726300**

## Roof Top 220v

### Roof Top 220v

The mains powered rooftop is available with 3 power outputs form 1.65kw to 2.7kw. The unit can be powered from mains supply or a generator.

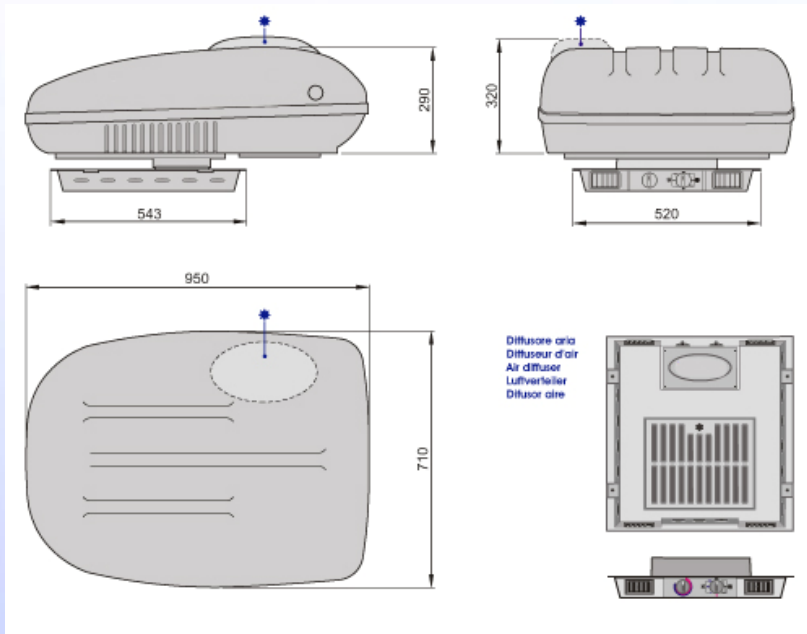

- |  |
|--|
| * Roof Cut Out From 360mm x 360mm to 400mm x 400mm |
| * Options for 1.65KW / 2.1KW / 2.7KW cooling       |
| * Options for 1.6KW heating                        |
| * Power Consumption 740W / 940W / 1180W            |
| * Weight 39KG to 41KG                              |
| * Air Flow 420m3/h                                 |
| * Working Voltage 220 AC / 50Hz                    |

### Roof Top 220v + Engine Compressor

The twin power rooftop unit allows A/C operation from compressor on the engine whilst in motion and A/C power from 220v supply when stationary .

- |   |
|---|
| * Roof Cut Out From 360mm x 360mm to 400mm x 400mm                |
| * Options for 1.65KW / 2.1KW / 2.7KW cooling From 220v            |
| * 6KW cooling from compressor on engine                           |
| * Options for 1.6KW heating                                       |
| * Power Consumption 220v 840W / 990W / 1230W & Compressor 37 amps |
| * Weight 48KG   |
| * Air Flow 220v 500m3/h & Compressor 600m3/h                      |



Reader Air Conditioning  
 Unit 3 Boundary Business Centre Boundary Way  
 Woking Surrey GU21 5DH England  
 Tel: +44 (0)1483 726300  
 Fax: +44 (0)1483 729300  
 sales@readerair.co.uk  
 www.readerair.co.uk